

Using Burp Valves with 850e
Revision B
March 14, 2018
Scribner Associates, Inc.

General:

850e models not equipped with the Wet/Dry (Humidifier Bypass) option can be used with user-supplied anode and cathode valves for burp/purge functions. This document describes how to connect these valves to the Auxiliary Signals connector of the 850e. Models equipped with the Wet/Dry option cannot be used with burp valves.

Auxiliary Signals Connector:

The signals required to control external valves are available from the Auxiliary Signals connector on the rear panel of the 850e. Other equipment can still be connected to other pins on the connector.

Wiring and Components Needed:

Wire the solenoid valves to the Auxiliary Signals connector as shown in Figure 1. The solid-state relays (SSRs), shown in Figure 1, must have ratings and heat sinks appropriate for the voltage and current ratings of the solenoid valves used. The SSR control inputs should operate with as low as 3.5 volts DC and draw no more than 10mA. The valve should be opened (burp) when energized.

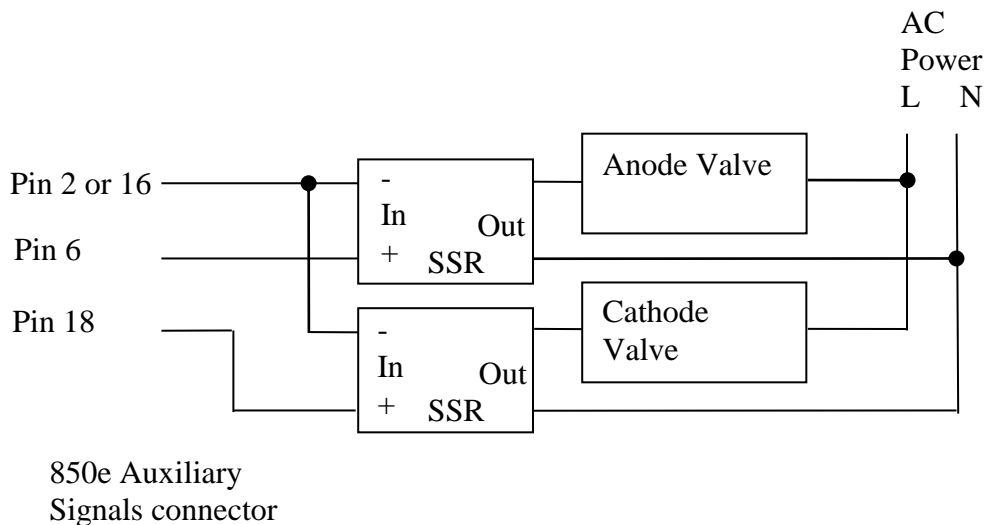

Figure 1 – Valve Wiring

Software Configuration:

Locate the Fuel Configuration tab of the Instrument Configuration menu. Check the boxes for Anode and Cathode Burp valve and uncheck the Wet/Dry and Aux Relay boxes. Note that if no box is checked for the Cathode side, the Cathode valve output will act as an alarm output, so it is important that these boxes are checked if burp valves are used. When the software is restarted, the purge (burp) settings will appear in the Setup Fuel menu.